

VALVE REGULATED LEAD ACID BATTERY (V.R.L.A.)

ADVANCED GEL TECHNOLOGY (AGM + GEL)

SUPERIOR DISCHARGE PROFILE

The Power Solar Advanced Gel batteries are designed and manufactured to handle every aspect of the demanding solar industry. The PSG series is built to withstand the wide range of environments, storage, extreme operating conditions and charge/discharge cycles that Solar applications require.

Features

- Advanced Gel Technology, provides deep cycle capability and better recharge profile throughout the life of the battery.
- Gas recombination greater than 99%
- Maintenance free construction. Needs no water additions and will not allow electrolyte spills.
- Shock absorbent polypropylene plastic. Resistant to extreme temperatures and vibration.
- Operates at a low internal pressure.
- Thermally welded case to cover bond, eliminates the risk of acid and electrical leaks.
- Oversized internal components insures minimal voltage drop and more power availability.
- Each cell has a low pressure safety release venting system to prevent explosions, recognized per U.L. 924.
- Industrial grade battery plates
- Puncture proof separator
- Measured high vacuum acid fill, reduces electrical variability between cells
- Can be used in any position, except upside down.
- Lifting handle
- 100% recyclable materials.

Specifications

Cells per unit	6
Nominal voltage	12
Terminal Type	1/4" stainless steel stud
Capacity @ 77°F (25°C) to 1.75v.p.c.	110 AH (20 Hours) 122 AH (100 Hours)
Short circuit current	4182 amps
Max discharge rate(1min rate)	489 amps
Impedance @ 77°F 25°C	3.60 milliohms
Electrolyte (S.G.)	1.300
CA (MCA) @ 32°F	1190
Reserve Capacity 25 amp load to 10.5 volts	200
Ideal operating temperature range	68°F (20°C) to 77°F (25°C)
Extended operating temperature range	Discharge: -40°F to +140°F Charge: -60°F to +160°F
Float Voltage	2.25 to 2.3 Volts Per Cell
Cycle Service Voltage	2.33 to 2.36 Volts Per Cell
Maximum charging rate	Cycle - 22 amps Float - 18 amps
Discharge Rate to 1.75 Volts Per Cell	3 hours - 28.2 5 hours - 18.2 10 hours - 9.8
Weight lbs	81.8
Length x Width x Height case (Height to the top of the terminals)	13.5" x 6.76" x 8.38" (9.31")



Battery Dimensions

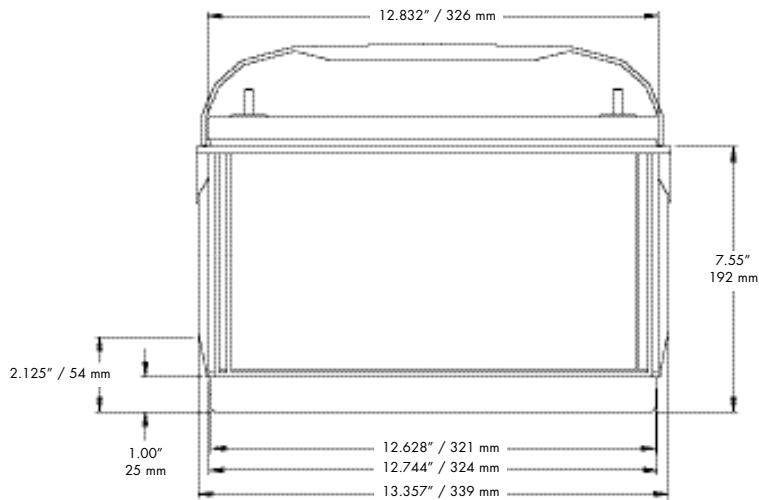

**SIDE VIEW
with Optional Handle**

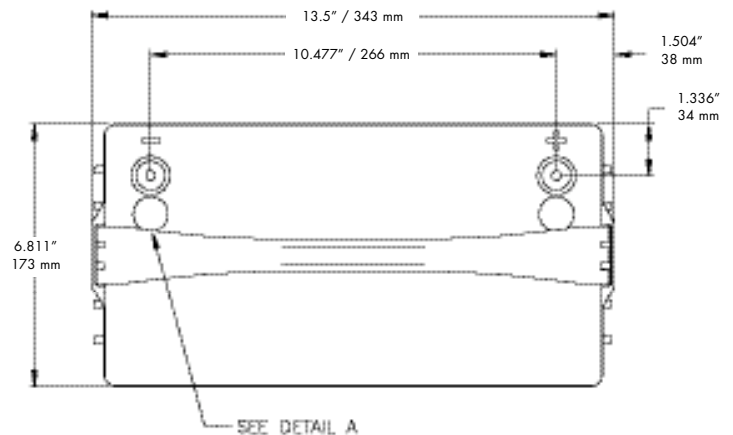

TOP VIEW

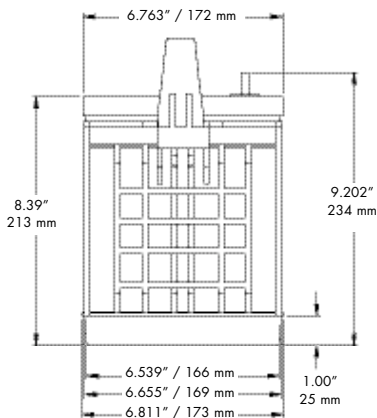

SIDE VIEW

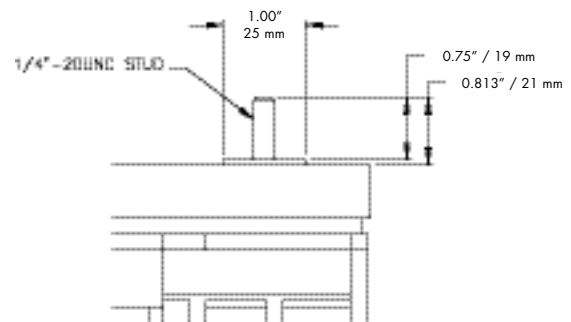

STUD POST TERMINAL DETAIL

Cycle Life vs. Depth of Discharge

15% DOD	2200 cycles
25% DOD	1700 cycles
50% DOD	900 cycles
80% DOD	600 cycles

No transport restrictions

- Surface transport. Classified as non-hazardous material as relates to DOT-CFR Title 49 part 171-189.
- Maritime transport. Classified as non-hazardous material as per IMDG amendment 27.
- Air transport. Complies with IATA/ICAO, special provision A67.

U.S.A.
Power Battery Company, Inc.
25 McLean Blvd.
Paterson, N.J. 07514-1507
Phone: (973) 523-8630
Fax: (973) 523-3023
E-mail: sales@powbat.com
Website: www.powerbattery.com

CANADA
Power Battery (Iberville) Ltd.
770 Thomas Ave.
Saint-Jean-sur-Richelieu, Québec, J2X 5E7
Phone: (450) 346-3273
Fax: (450) 346-8003
E-mail: sales@powbat.com
Website: www.powerbattery.com

UK
Power Batteries Ltd.
Premier Way, Abbey Park Industrial Estate
Romsey, Hampshire, SO51 9AQ
Phone: +44 (0)1794 835900
Fax: +44 (0)1794 835910
E-mail: sales@powbat.co.uk
Website: www.powbat.co.uk

1813-2-0710